

M4080

Hemisferic

Hemisferic Linear Pendant 28W LED 110cm Bar 3000K, 2520lm, Satin Aluminium/Frosted Acrylic, 3yrs Warranty



LINE DRAWING

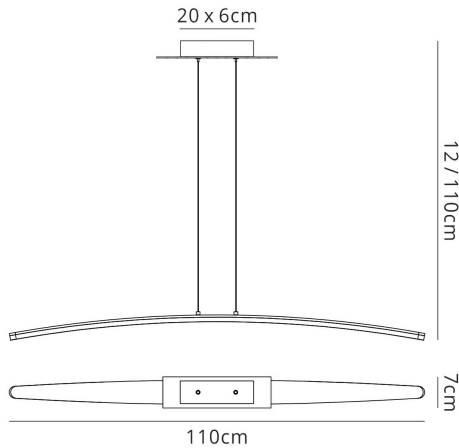

[Click to view the full product details](#)

DATA SHEET

MARKETING INFORMATION

Brief Description	Hemisferic 28W LED Pendant Light
Catalogue Description	LED Large Linear Pendant

PHYSICAL CHARACTERISTICS

Colour Finish	Satin Aluminium
Colour Finish 2	Frosted White
Ceiling Mountable	Yes

MECHANICAL SPECIFICATION

Item Nett Weight (kg)	2.27kg
Length (mm)	70mm
Width (mm)	710mm
Minimum Drop (mm)	120mm
Maximum Drop (mm)	1100mm
Materials Used	Iron, Acrylic

ENERGY SPECIFICATION

Energy Class	A++ to A
--------------	----------

LAMP SPECIFICATION

No: of Lamp	1
Lamp Socket	Integral LED
Recommended Lamp	Integral LED
Max Wattage Lamp (W)	28W
Lamp Included	Yes - Integrated
Type of Lamp Included	Integrated LED
Colour Temperature (K)	3000K Warm White (±5%)

LED SPECIFICATION

Average Life of LED (hrs)	25000hrs
Type of LED	SMD

OPTICAL SPECIFICATION

Beam Angle (°)	120°
System Flux (lm)	2520lm (±5%)
CRI	=80

DRIVER SPECIFICATION

Inspired Lighting Ltd. are continually developing and improving their products.
Technical specifications subject to change without prior notice.

M4080

Hemisferic

Driver Included	Yes - Internal
Type of Driver	Constant Current

ELECTRICAL & SAFETY SPECIFICATION

Protection Class	Class 1 - Earth Connection Required
Total Power Consumption (W)	28W (±5%)
Input Voltage (V)	220-240V~50/60Hz
Dimmable	No
IP Rating	IP20

QUALITY STANDARDS

Average Life (hrs)	25000hrs
Warranty (yrs)	3yrs
CE	Yes
Rohs	Yes
TUV	Yes

CARTON INFORMATION

Number of Cartons	1
Carton CBM	0.0345
Carton Gross Weight (kg)	3.04kg (±5%)

ADDITIONAL INFORMATION

UK Commodity Code	9405119090
Country of Origin	China

OVERVIEW

This sleek design is the epitome of minimalist chic. A harmonious combination of anodized aluminium and high quality acrylic gives a universal finish. Hemisféric is a comprehensive range offering numerous possibilities for your chosen interior. The symmetry and gentle curve of this design creates a subtle yet bold statement. A most impressive floor lamp has an inline dimmer for complete flexibility to create that perfect ambience. All Mantra LED products carry a 3 year warranty.

Inspired Lighting Ltd. are continually developing and improving their products.
Technical specifications subject to change without prior notice.