

M3855/CS

Tiffany Polished Chrome-Cream

Tiffany Linear Pendant 3+3 Light E27+G9 Line, Polished Chrome With Cream Shades & Clear Crystal

LINE DRAWING

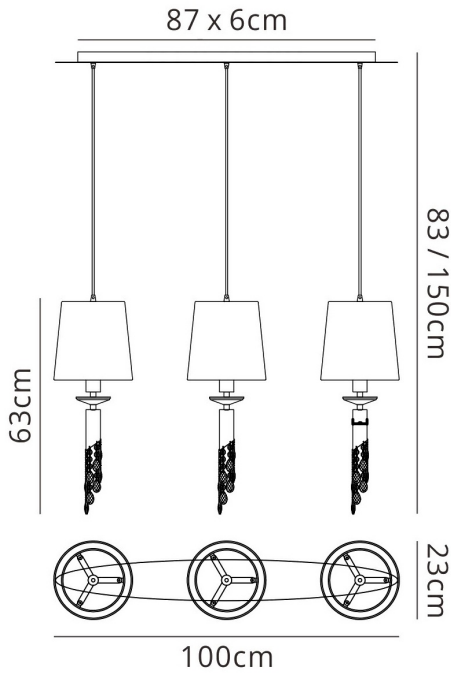

[Click to view the full product details](#)

DATA SHEET

MARKETING INFORMATION

Brief Description	Tiffany Crystal Pendant 3+3 Light
Catalogue Description	3+3 Light Linear Pendant

PHYSICAL CHARACTERISTICS

Colour Finish	Polished Chrome
---------------	-----------------

MECHANICAL SPECIFICATION

Item Nett Weight (kg)	5kg
Length (mm)	1000mm
Width (mm)	230mm
Minimum Drop (mm)	630mm
Maximum Drop (mm)	1500mm
Materials Used	Iron, Crystal, Organza Ribbon

ENERGY SPECIFICATION

Energy Class	A++ to D
--------------	----------

CRYSTAL SPECIFICATION

Type of Crystal	K9
Crystal Colour Finish	Clear

LAMP SPECIFICATION

No: of Lamp	3
Lamp Socket	E27
Recommended Lamp	LED (Candle C35)
Max Wattage Lamp (W)	23W
Lamp Included	No
No: of Lamp 2	3
Lamp 2 Socket	G9
Recommended Lamp 2	750320023
Max Wattage Lamp 2 (W)	3W
Lamp 2 Included	No

ELECTRICAL & SAFETY SPECIFICATION

Protection Class	Class 1 - Earth Connection Required
Total Power Consumption (W)	Dependent On Lamps Used (±5%)
Input Voltage (V)	220-240V~50/60Hz
Dimmable	Yes - Suitable Lamps & Dimmer

Inspired Lighting Ltd. are continually developing and improving their products.
Technical specifications subject to change without prior notice.

M3855/CS

Tiffany Polished Chrome-Cream

	Required
Dimmer Included	No
IP Rating	IP20
QUALITY STANDARDS	
Warranty (yrs)	1yr
CE	Yes
PRODUCT COMPONENT SPECIFICATION	
Shade Colour	Cream
Plate Dimensions (mm)	L:870mm, W:40mm, H:30mm
Bracket Dimensions (mm)	785mm long x 20mm wide
CARTON INFORMATION	
Number of Cartons	1
Carton CBM	0.1796
Carton Gross Weight (kg)	6.7kg (±5%)
ADDITIONAL INFORMATION	
UK Commodity Code	9405195000
Country of Origin	China

OVERVIEW

Tiffany is most definitely a rare and grandeur lighting collection with an extensive range of products. It combines E27 or E14 lamp holders on the upper level which are accompanied by discreet G9 lamp holders that are housed at the lower level within each tube below. This ingenious concept directly enhances the sparkle of its crystal carvings, as well as illuminating the surfaces below. The angled tubes are a fascinating design followed by the crystal strands creating a cascade of luxurious colour. The full collection is available in either polished chrome with white shades, antique brass with a bespoke soft bronze colour shade or an exquisite French gold with cream shades. With the option to choose the alternative colour shade creates the flexibility to design the perfect solution. Tiffany is prestigious range of lighting that redefines elegance.